



# PLZ-5WH SERIES



Up to  
**100kW**  
Max Power  
\*5 Unit Parallel

## DC ELECTRONIC LOAD

### Compact High Voltage DC Electronic Load

# PLZ-5WH Series



Operating voltage: 10V – 800V (Min. 1.5V)  
20kW in a single unit (PLZ20005WH)  
100kW/2000A with parallel operation (Max. 5 units)  
LAN (LXI)/USB/RS232C standard digital interface \*GPIB optional  
Synchronized operation  
Arbitrary I-V characteristic (ARB) mode  
Data-logging: voltage/current/power measurements/capacity/Energy



# Compact, High Power Maximum Operating Voltage **800V**

Ideal for high capacity power supply and rechargeable battery evaluation!  
Testing with hyper-realistic load simulation made possible!



**PLZ20005WH**

**20kW**

**PLZ12005WH**

**12kW**

The PLZ-5WH high power DC electronic load series is where durable, reliable ingenuity meets multifunctional and high power design. Up to 20kW can be achieved with a single unit. Thanks to the highly power dense design of the PLZ-5WH, this series can sink up to 20kW of power in a single unit. Load simulation can be achieved faster than ever before thanks to the reliable, high speed design of the PLZ-5WH current control circuits. Accurate current measures can be made with extremely high setting resolution. A color LCD display allows for highly visible, user-friendly front panel operation. RS232C, USB, and LAN digital interfaces are included as standard for simple integration into any system.

## Compact High Voltage DC Electronic Load **PLZ-5WH Series** NEW

Model	Max Current	Max Voltage	Power
PLZ12005WH	240A	10V to 800V	12kW
PLZ20005WH	400A		20kW

- Operating voltage: 10V – 800V (Min. 1.5V)
- 20kW in a single unit (PLZ20005WH)
- 100kW/2000A with parallel operation (Max. 5 units)
- Synchronization: Load ON/OFF control and sequences can be synchronized among multiple units
- Arbitrary IV characteristic (ARB) mode
- User-friendly color LCD display
- Data-logging: voltage/current/power measurements (Measurement display, programmable internal memory)
- LAN (LXI)/USB/RS232C standard digital interface \*GPIB optional

Application	EV, HEV high voltage converter evaluation testing, solar power generation, fuel cell, secondary fuel cell evaluation testing, high voltage device evaluation testing, etc.
-------------	--

**[functions]**

- Parallel Operation ● Synchronized operation ● Data Logging function ● Communication function ● Current monitor output ● Soft start function
- Elapsed time display and Cutoff function ● Remote sensing function ● Load on/off operations ● Range control input ● Trigger input ● Alarm input
- Alarm status output ● Load-on status signal output ● Range status output ● External voltage control input(CC, CR, CV and CP modes)
- Overvoltage protection (OVP) ● Overcurrent protection (OCP) ● Overpower protection (OPP) ● Overheat protection (OTP) ● Undervoltage protection (UVP)
- Reverse connection detection (REV) ● Watchdog protection (WDP)

## Flexible communication interface

LAN, USB and RS232C standard digital interface. \*GPIB Option



Use a browser from a PC, smartphone, or tablet to access the web server built into the PLZ-5W series for convenient control and monitoring.

[Recommended browser]

- Internet Explorer version 10
- Internet Explorer version 9.0 or later
- Firefox 8.0 or later
- Safari/Mobile Safari 5.1 or later
- Chrome 15.0 or later
- Opera 11.0 or later

\*Connecting with a smartphone, tablet, etc. requires a Wi-Fi environment (wireless LAN router etc.).

## Parallel operation

### Up to 100kW with parallel operation (Max. 5 units)

The PLZ12005WH/PLZ20005WH can be connected in parallel to increase the maximum system capabilities up to 100kW. While connected in parallel, one master unit has complete control of the slave unit(s), allowing the user to control the entire system and monitor all data from the master unit's front panel. Parallel operation requires one optional parallel cable for each slave unit (up to 4). The master and slave unit settings are configured automatically upon connection. Standalone settings automatically return to normal after removing parallel cable and restarting the unit.

Maximum current and power during parallel operation using the same model

Parallel Operation Number	Maximum current / Maximum power	
	PLZ12005WH	PLZ20005WH
2	480A / 24kW	800A / 40kW
3	720A / 36kW	1200A / 60kW
4	960A / 48kW	1600A / 80kW
5	1200A / 60kW	2000A / 100kW

## Maximum Slew Rate of 20 A/μs

The PLZ-5WH series boasts a 20 μs rise time, easily satisfying the critical needs of power supply evaluation tests demanding a fast transient response.

\*When using the PLZ20005WH

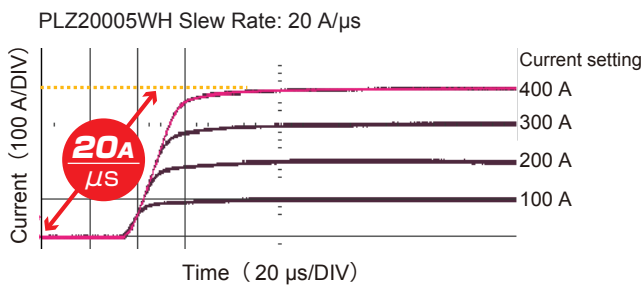

## Wide ranging operation voltage up to 800 V.

Operating voltage ranges from 10 V to 800 V.

Minimum operating voltage required to sink current is 1.5 V.

[Operating area of PLZ20005WH]

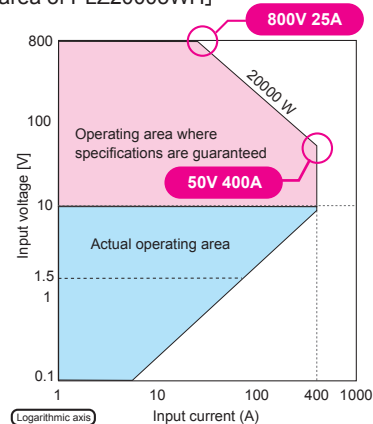

## Rear Panels



PLZ20005WH



PLZ12005WH

## Operation modes

The following five operation modes are available on the PLZ-5WH. In addition, in operation modes other than CV mode, it is possible to apply a current (UVPL) or load off (UVPT) by applying a current to reach the target setting voltage.

Constant current (CC) mode	A current value is specified and the current is kept constant even when the voltage changes.
Constant resistance (CR) mode	A conductance value is specified and the PLZ-5W sinks current proportional to the voltage variation.
Constant voltage (CV) mode	A voltage is specified and the PLZ-5W sinks current so that the voltage at the load input end of the PLZ-5W is constant.
Constant power (CP) mode	A voltage is specified and the PLZ-5W sinks current so that the power consumed inside the electronic load is constant.
Arbitrary I-V characteristics (ARB) mode	The desired load characteristics can be set by specifying multiple arbitrary voltage values and current values as I-V characteristics.

## Adjustable slew rate

With the PLZ-5WH, the slew rate, or speed at which current changes, is programmable. The slew rate setting will function under the following circumstances:

- When settings are applied to change the current value (including the pulse function).
- When the current value is changed via external control in CC mode
- When the current value is changed while the load is on.

The slew rate can be set as an amount of current change per unit of time, and measured in the same units for both rise and fall times.

Item	PLZ12005WH	PLZ20005WH
Operation mode	CC	
Operating range	0.01 A/ $\mu$ s ~ 12 A/ $\mu$ s	0.02 A/ $\mu$ s ~ 20 A/ $\mu$ s
Resolution	0.2 mA/ $\mu$ s	0.5 mA/ $\mu$ s
Setting accuracy*1	$\pm$ (10 % of set +20 $\mu$ s)	

\*1 The time it takes to shift from 10% to 90% when the current is Varied from 0% to 100% of the rated current.

## Load on/off operation

The following load on/off settings are available in addition to standard operations that can be carefully adjusted to fit the needs of any test environment.

- Start with "load on" when power is turned on
- Display elapsed "load on" time
- Auto "load off" when time limit is reached
- Control "load on/off" with external controls such as relays

## Arbitrary I-V characteristics (ARB) mode

In ARB mode arbitrary I-V characteristics can be set by entering multiple I-V points (voltage and current value set points). 3 to 100 points can be registered and the spaces between all points are automatically linearly interpolated. The minimum voltage (0.00V) and maximum voltage (808.00V) are fixed. This mode can be used for the simulation of LED drivers and other DUT's with non-linear characteristics.

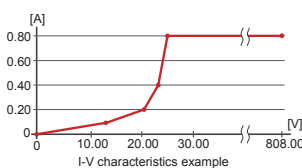

Example of settings (values with an asterisk are fixed)

Voltage [V]	Current [A]
0.00*	0.00*
12.00	0.10
20.50	0.20
23.00	0.40
24.50	0.80
808.00*	0.80

## Pulse function

The pulse function is defined as the rapid transition of two settings alternating repeatedly. This setting is suitable for dynamic transient tests for high capacity power supplies and batteries. During pulse operation, a trigger signal is output from the TRIG OUT connector on the front panel (p.36). These settings can be changed regardless of whether the load is on or off in both CC and CR modes. The pulse amplitude can be set either as a number or a percentage of the load setting values.

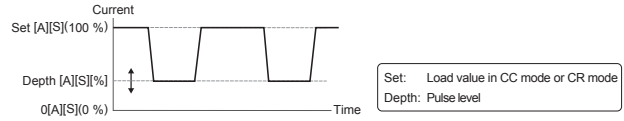

During pulse operation, the front panel TRIG OUT connector outputs a trigger signal for 1 $\mu$ s when the current is changed from LOW (Depth) to (High).

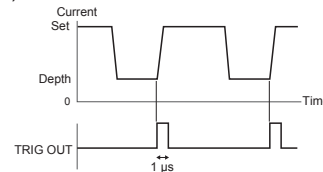

Operation mode	CC,CR
Frequency setting range	1.0 Hz ~ 10.0 kHz
Frequency setting resolution*1	1Hz ~ 10 Hz
	11Hz ~ 100 Hz
	110 Hz ~ 1000 Hz
	1.1kHz ~ 10.0kHz

\*1 (Reference) The resolution actually set in the device is period resolution  $\Delta T = 1 \mu s$ , as shown in the equation below. For example, if you specify 9300 Hz, the period set in the device will be  $n \times \Delta T = 108 \times 1 \mu s = 108 \mu s$  (where n is a number set in the device). Converted to frequency, this becomes  $1/108 \mu s = 9259$  Hz.

## Sine Function

The sine function alternates the current sinusoidally. This is ideal for superimposed ripple testing for high capacity power supplies and batteries. During sine operation, the front panel TRIG OUT connector outputs a trigger signal (p.36). These settings can be changed regardless of whether the load is on or off in CC mode, but the slew rate cannot be set. The sine amplitude can be set as a number.

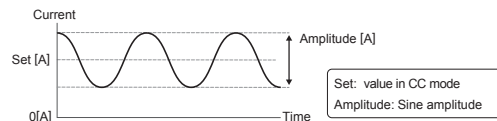

During sine operation, a trigger signal is output from the TRIG OUT connector on the front panel for 1 $\mu$ s when the current passes through the set value on the rising edge (sine wave phase at 0 degrees).

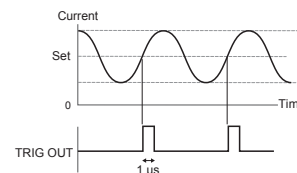

Operation mode	CC
Frequency setting range	1.0 Hz ~ 1kHz, 2kHz, 5kHz, 10 kHz
Frequency setting resolution*1	1Hz ~ 10 Hz
	20 Hz ~ 100 Hz
	200 Hz ~ 1000 Hz

\*1 (Reference) The resolution actually set in the device is period resolution  $\Delta T = 20 \mu s$ , as shown in the equation below. For example, if you specify 900 Hz, the period set in the device will be  $n \times \Delta T = 56 \times 20 \mu s = 1120 \mu s$  (where n is a number set in the device). Converted to frequency, this becomes  $1/1120 \mu s = 893$  Hz.

## Sequence Function

The operator can execute a long sequence of predetermined values with the sequence function. A sequence consists of programs and steps. A program is a collection of steps, which are executed in order, one by one, starting from step 1. The program is considered complete after the last step in the program is executed.

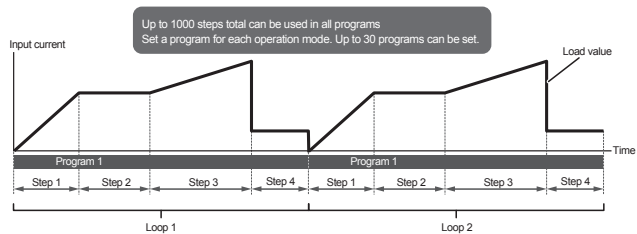

Setting range	Setting	Description
By step	Load value	Current, conductance, voltage, power. The values that can be set depend on the current operation mode.
	Slew rate	Sets the speed of change when the current is changed.
	Step execution time	0.000050 s to 3600000 s (50 μs to 1000 h), resolution: 1 μs
	Load on/off control	To turn the load on, set the load setting transition method to step or ramp.
	Other	Trigger signal setting, trigger signal output
For each program	Number of loops of program	1 to 100000 repetitions, or infinite repetitions.
	Protection function	Specifies the value at which a protection function (OCP, OPP, UVP) is activated.

### ● TALink

The TALink (Transient Acquire Link) trigger makes it possible to log data in PLZ-5WH in synchronization with the sequence steps. Logged data can then be accessed through communication with the PLZ-5WH and saved to a USB as a CSV file.

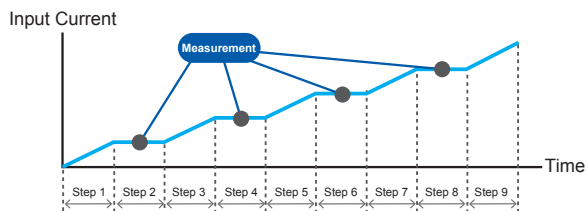

## Data Logging Function

The data logging function allows the user to log measurement values in the internal memory, and display logged data on an LCD screen (Table) as a chart (Chart). It can also be stored in CSV format on a USB and acquired through communication between the PLZ-5WH and a PC. By setting measurement logging conditions, the timing for data logging for each measurement can be controlled and synchronized between synced devices. Additionally, log measurements can be made when the load is off, meaning that test results such as battery discharge capacity (Ah) can be measured and stored as CSV data onto a USB.

## Integrated Data Function

Time elapsed, integrated current and integrated power can be logged. Logging (integration) can be coordinated to start/finish when the load turns on/off or during the start or end of a sequence. Logging can also be controlled arbitrarily.

## Remote sensing function

With remote sensing, the voltage measurement point can be changed from the load input terminal to the DUT sensing point. By connecting the sensing leads to the DUT, the effects of voltage drops caused by resistance in the load cables can be reduced and the load current stabilized. To activate remote sensing, connect the sensing cables to the sensing terminals of the PLZ-5WH at the DUT end, and enable the remote sensing function.

- Remote sensing input rated voltage : 800V

## Cutoff Function

The cutoff function allows the user to enable load off once the desired time/voltage drop/integrated current/integrated power has been reached after load on. Multiple factors can be selected, with load off being implemented after the first requirement is met.

Elapsed time		The load turns off when the elapsed time value reaches the specified value.
	Setting range	0s ~ 3600000 s (1000h 0min 0s)
Voltage drop		The load turns off when the voltmeter value reaches the specified value.
	Setting range	0.00 V ~ 800.00 V
Integrated current		The load turns off when the ampere-hour meter value reaches the specified value.
	Setting range	0.000 mAh ~ 800.000 kAh
Integrated power		The load turns off when the watt-hour meter value reaches the specified value.
	Setting range	0.000 Wh ~ 400.000 MWh

## Synchronized operation

The following synchronization features are available when simply connecting the PLZ-5WH with other equipment using a communication cable. PLZ12005WH and PLZ20005WH can be connected. The synchronization feature is available during parallel operation.

- Synchronizing load on/off among multiple pieces of equipment.
- Synchronizing measurements (remote control).
- Synchronizing the start time and resume time for sequences across multiple units.

### 【Connection example】

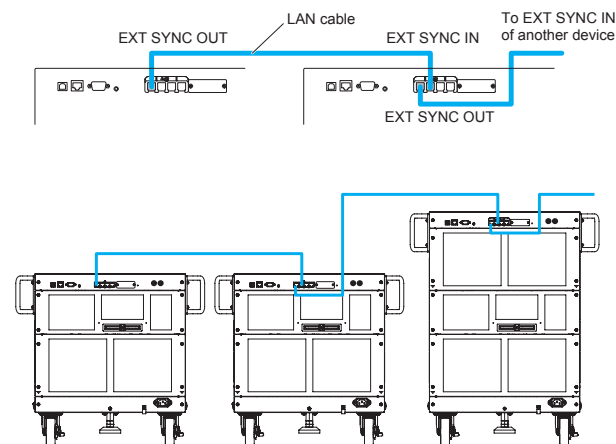

## External Control

The PLZ5WH can be controlled and monitored with an external device. The external control terminals are isolated from the load input terminals.

## Setup Memory

The setup memory can store up to 20 sets of the settings listed below or alternatively saved on a USB memory device.

- Operation mode
- Load values (current, voltage, conductance, power)
- Slew rate
- Pulse amplitude (current/conductance or percentage)
- Pulse interval (frequency/time of one cycle and duty cycle/operating time on the high side)
- Sine amplitude (current)
- Sine frequency
- Alarm operating conditions
- Content of ABC preset memories

A file saved on the PLZ-5W (PLZ205W, PLZ405W, PLZ1205W) can be transferred to the PLZ-5WH via a USB memory device. If the UVP is set to "limit" on the PLZ-5WH, this will be changed to +CV mode on the PLZ-5W.

## ABC Preset memories

Three setting values can be stored in preset memory slots A, B, and C. All saved settings can be accessed at the press of a button, which is perfect for when you want to quickly switch between three sets of values.

## Soft start function

The soft start feature controls the rise time of the load current. The soft start feature can be activated when the following conditions are met:

- The rise time of the soft start has been set.
- "Load on" while in CC Mode.
- Soft start input settings start from zero input and end equal to or above the minimum operating conditions.

This function can be used if the output of the DUT becomes unstable when the load current rises sharply, or when the operator wishes to delay the current change on startup to prevent the DUT's overcurrent protection circuit from being activated.

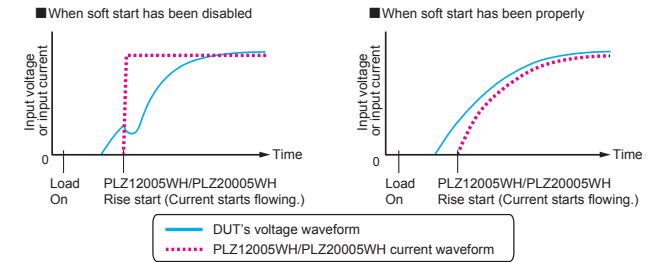

Operation mode	CC
Time setting range resolution	500 μs, 1ms, 2ms, 5ms, 10 ms, 20 ms, 50 ms, 100 ms, and Off

## Current and Voltage Monitor

In addition to the conventional current monitor output, voltage monitor output (0V to 8V/0V to 800V) has been added to the front BNC connector.

## Diverse protection functions, Other functions

Overcurrent protection (OCP), Overpower protection (OPP), Overvoltage detection(OVP), Undervoltage protection (UVP), Overheat detection(OTP), Reverse-connection detection(REV), Alarm input detection, Configuration setting, USB Keyboard Compliant.

## Application

### Battery Discharge Testing

Battery discharge test can be conducted and results saved without a PC. The acquired data can be saved in CSV format on USB memory.

Battery

DC Electronic Load PLZ-5WH Series

I/V Curve(sequence)  
Cut conditions : Time  
Data display : chart  
Sample : 1

Volmetric property(Constant current)  
Cut conditions : Voltage or capacity (Ah)  
Data display : table  
Sample : 5

## ● EV Charger Aging Tests

LV124 Standard L-02 Life test - high-temperature endurance test (Durability – Heat) < Life test >

< Combination of AC power source and electronic load equipment >

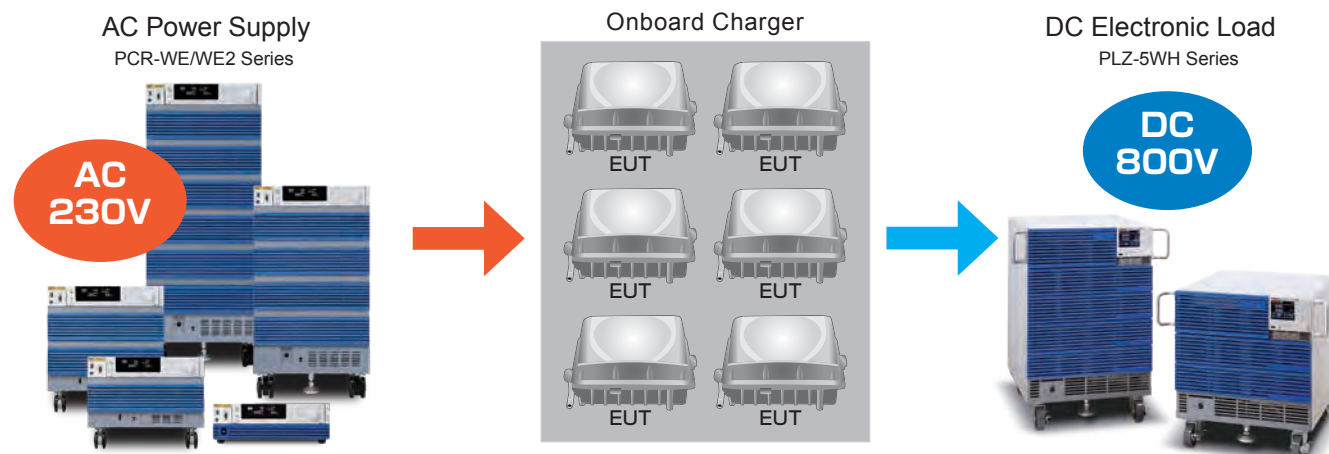

\*DUT must function completely before/during/after testing (n=6 units)

## ● Motor Surge Absorption

The PLZ-5WH can protect the power source and ECU from regenerative current during a brushless motor test. This is performed in CV mode and can prevent oscillation depending on the response settings.

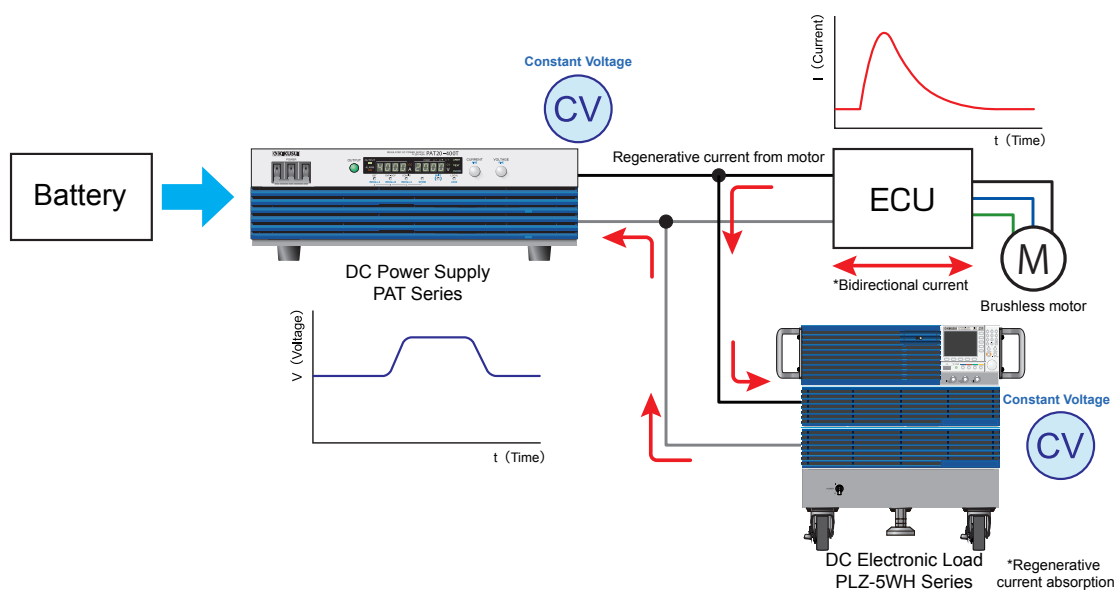

## ● DC-DC Converter Evaluation

DC-DC converter performance tests vital for automotive electric components can easily be carried out by controlling the converter input (DC power supply) and output (DC electronic load). The DC power supply and electronic load can be started up simultaneously for variation tests and efficiency tests.

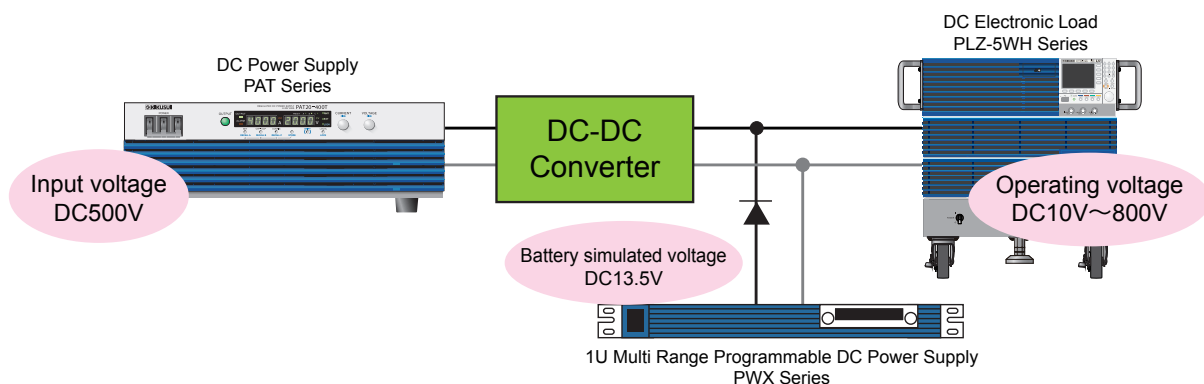

Unless specified otherwise, the specifications are for the following settings and conditions.

- The product is warmed up for at least 30 minutes.
- TYP: These are typical values that are representative of situations where the product operates in an environment with an ambient temperature of 23 °C. These values do not guarantee the performance of the PLZ12005WH/PLZ20005WH.

- set: Indicates a setting.
- range: Indicates the rated value of each range.
- reading: Indicates a readout value.
- rating: Indicates a rated value.
- Open: Indicates equivalence to the state in which the load input terminals are opened.
- Using DC INPUT

## ■ Ratings

Item	PLZ12005WH	PLZ20005WH
Operating voltage (DC)	10 V to 800 V	
Current	240 A	400 A
Power	12000 W	20000 W
Load input terminal's isolation voltage	±800 V	
Minimum operating voltage	At the rated current	10 V
	When the current begins to flow	1.5 V or less

## ■ Constant current (CC) mode

Item	PLZ12005WH	PLZ20005WH
Operating range	0 A to 240 A	0 A to 400 A
Setting range	0 A to 242.400 A	0 A to 404.00 A
Resolution	5 mA	10 mA
Setting accuracy	± (0.2 % of set + 0.1 % of rating)	
	Parallel Operation	± (0.4 % of set + 0.2 % of rating)

## ■ Constant resistance (CR) mode

Item	PLZ12005WH	PLZ20005WH	
Operating range*1	H range	6000 mS to 0 S	
	L range	60 mS to 0 S	
Setting range	H range	6060.0 mS to 0 S	
	L range	60.600 mS to 0 S	
Resolution	H range	0.2 mS	
	L range	0.002 mS	
Setting accuracy*2	H range	± (0.5 % of set + 0.5 % of rating)	
	L range	± (0.5 % of set + 0.2 % of rating)	
	Parallel Operation	H range	± (1.0 % of set + 1.0 % of range)
		L range	± (1.0 % of set + 0.4 % of range)
Response speed	NORM / FAST		

\*1 Conductance [S] = input current [A]/input voltage [V] = 1/resistance [Ω]

\*2 Converted value at the input current. At the sensing terminals during remote sensing.

## ■ Constant voltage (CV) mode

Item	PLZ12005WH	PLZ20005WH
Operating range	10 V to 800 V	
Setting range	0 V to 808.00 V	
Resolution	20 mV	
Setting accuracy*1	± (0.05 % of set + 0.05 % of rating)	
	Parallel Operation	± (0.1 % of set + 0.1 % of rating)
Response speed	NORM / FAST	

\*1 With the input voltage within the operating range, and at the sensing terminals during remote sensing.

## ■ Constant power (CP) mode

Item	PLZ12005WH	PLZ20005WH
Operating range	0 W to 12000 W	0 W to 20000 W
Setting range	0 W to 12120 W	0 W to 20200 W
Resolution	0.5 W	0.5 W
Setting accuracy*1	±(0.5 % of rating + 0.2 A × Vin)	±(0.5 % of rating + 0.4 A × Vin)
Parallel Operation	±(1 % of range + 0.1 % current rating × Vin)	

\*1 Vin: Load input terminal voltage or SENSING terminal voltage.

## ■ Arbitrary I-V characteristics (ARB) mode

Item	PLZ12005WH	PLZ20005WH
Operating range	3 to 100 points of current values can be specified for the input voltage. Linear interpolation is applied between specified points.	
Response speed	500 μs, 1 ms, 2 ms, 5 ms, 10 ms, 20 ms, 50 ms, 100 ms, or off	

## ■ Measurement function

### [Voltmeter]

Item	PLZ12005WH	PLZ20005WH
Display	0.00 V to 800.00 V	
Resolution	10 mV	
Accuracy	±(0.05 % of reading + 0.05 % of range)	
	Parallel operation(TYP)	±(0.1 % of reading + 0.1 % of range)

### [Ammeter]

Item	PLZ12005WH	PLZ20005WH
Display	0.00 A to 240.00 A	0.00 A to 400.00 A
Resolution	10 mA	
Accuracy	±(0.2 % of reading + 0.1 % of range)	
	Parallel operation(TYP)	±(0.4 % of reading + 0.2 % of range)

### [Power display]

Item	PLZ12005WH	PLZ20005WH
Display	Displays the product of the voltmeter reading and ammeter reading	

### [Measurement trigger]

Item	PLZ12005WH	PLZ20005WH
Trigger Source	Immediate / BUS / DIGITAL2 / MSync / TALink / LoadOff	
Trigger Count	1 to 65536	
Trigger Delay	0 μs to 100 s	
Interval	Disable / Enable	
Interval Time	10 μs to 3600 s	
Sense Aperture	10 μs to 1s	

## ■ Pulse function

Item	PLZ12005WH	PLZ20005WH
Operation mode	CC, CR	
Frequency setting range	1.0 Hz to 10.0 kHz	
Frequency setting resolution*1	1Hz ~ 10 Hz	0.1 Hz
	11Hz ~ 100 Hz	1Hz
	110 Hz ~ 1000 Hz	10 Hz
	11kHz ~ 10.0kHz	0.1 kHz
Frequency setting accuracy	1Hz ~ 5.0 kHz	± (0.5 % of set)
	5.1Hz ~ 10.0 kHz	± (1.0 % of set)
Duty cycle setting range, step	1Hz ~ 10 Hz	5.0 % ~ 95.0 %, 0.1 % steps
	11Hz ~ 100 Hz	
	110 Hz ~ 1000 Hz	
	11kHz ~ 10.0kHz	5% ~ 95 % *2, 1% steps
Switch value (Depth)*3	CC mode	0A ~ 242.40 A
	CR mode H range	6.0600 S ~ 0 S
	CR mode L range	60.600 mS ~ 0 S

\*1 (Reference) The resolution actually set in the device is period resolution  $\Delta T = 1 \mu s$ , as shown in the equation below. For example, if you specify 9300 Hz, the period set in the device will be  $n \times \Delta T = 108 \times 1 \mu s = 108 \mu s$  (where n is a number set in the device). Converted to frequency, this becomes  $1/108 \mu s = 9259 \text{ Hz}$ .

\*2 The minimum time span is 20 μs. The minimum duty cycle is limited by the minimum time span.

\*3 The switch value is limited to the set current or set conductance or less.

## ■ Sine function

Item	PLZ12005WH	PLZ20005WH
Operation mode	CC	
Frequency setting range	1.0 Hz ~ 1kHz, 2kHz, 5kHz, 10 kHz	
Frequency setting resolution*1	1Hz to 10 Hz	1 Hz
	20 Hz to 100 Hz	10Hz
	200 Hz to 1000 Hz	100 Hz
Frequency setting accuracy	300 Hz to 900 Hz	± (1.0 % of set)
	Other than above frequency	± (0.5 % of set)

\*1 (Reference) The resolution actually set in the device is period resolution  $\Delta T = 20 \mu s$ , as shown in the equation below. For example, if you specify 900 Hz, the period set in the device will be  $n \times \Delta T = 56 \times 20 \mu s = 1120 \mu s$  (where n is a number set in the device). Converted to frequency, this becomes  $1/1120 \mu s \approx 893 \text{ Hz}$ .



## ■ Slew rate

Item	PLZ12005WH	PLZ20005WH
Operation mode	CC	
Operation range	0.01 A/μs ~ 12 A/μs	0.02 A/μs ~ 20 A/μs
Resolution	0.2 mA/μs	0.5 mA/μs
Setting accuracy*1	± (10 % of set +20 μs)	

\*1 Time to change from 10 % to 90 % when the current is changed from 0 % to 100 % of the rated current

## ■ Soft start

Item	PLZ12005WH	PLZ20005WH
Operation mode	CC	
Time setting range	500 μs, 1ms, 2ms, 5ms, 10 ms, 20 ms, 50 ms, 100 ms, or off	

## ■ Alarm function

### [Alarm 1]

Item	PLZ12005WH	PLZ20005WH
Overvoltage detection	Turns off the load when a voltage that is 110 % of the rating or higher is applied.	
Reverse-connection detection	Turns off the load when approximately -1 % of the rated current flows through the load input terminals.	
Overheat detection	Turns off the load when the heatsink temperature reaches 100°C	
Alarm input detection	Turns off the load when a voltage between 0 V and 1.5 V is applied to ALARM INPUT (pin 6) of the EXT CONT connector.	
Parallel operation anomaly detection	Turns off the load in parallel operation mode when an anomaly occurs during communication, when the slave unit's power supply is interrupted, or when the slave unit's overheat detection is activated	

### [Alarm 2]

Item	PLZ12005WH	PLZ20005WH	
Overcurrent protection (OCP)	Setting range	0.00 A to 264.00 A	0.0 A to 440.0A
	Resolution	10 mA	100 mA
	Protection operation	Either load off or limitation can be selected	
Overpower protection (OPP)	Setting range	0W to 13200 W	0 W to 22000 W
	Resolution	1W	
	Protection operation	Either load off or limitation can be selected	
Undervoltage protection (UVP)	Setting range	0.00 V ~ 800.00 V, or off	
	Resolution	20 mV	
	Protection operation	Either load off or limitation can be selected	
Watchdog protection (WDP)	Setting range	1s to 3600 s, or off	
	Protection operation	Load off	

## ■ EXT CONT connector

Item	PLZ12005WH	PLZ20005WH
Load on/off control input	Logic level switchable. Pulled up to 5 V by a 10 kΩ resistor. The thresholds are HIGH: 3.5 V to 5 V, LOW: 0 V to 1.5 V.	
Alarm input	An alarm is activated with a voltage between 0 V and 1.5 V. Pulled up to 5 V by a 10 kΩ resistor. The thresholds are HIGH: 3.5 V to 5 V, LOW: 0 V to 1.5 V.	
Alarm clearing input	After an alarm occurs, eliminate the root cause of the alarm, and change the input to pin 5 of the EXT CONT connector from a low level signal to a high level signal. The alarm will be cleared on the rising edge of this signal. Pulled up to 5 V by a 10 kΩ resistor. The thresholds are HIGH: 3.5 V to 5.0 V, LOW: 0 V to 1.5 V.	
Trigger input	Paused sequence operation resumes when a voltage between 0 V and 0.8 V is received. Pulled up to 5 V by a 10 kΩ resistor. The thresholds are HIGH: 2 V to 5 V, LOW: 0 V to 0.8 V.	
External voltage control input (CC, CR, CP mode)	Controls the load settings of CC, CR, CP mode through external voltage input. The input impedance is approx. 10 kΩ. CC: The setting can be controlled in the range of 0 % to 100 % of the rated current through external voltage input of 0 V to 10 V. CR: The setting can be controlled in the range of 0 % to 100 % of the conductance setting through external voltage input of 0 V to 10 V. CP: The setting can be controlled in the range of 0 % to 100 % of the rated power through external voltage input of 0 V to 10 V.	
	Setting accuracy	±(1 % of range) (TYP value in CC mode)
External voltage control input (CV mode)	Controls the load setting of CC mode by adding current through external voltage input. Adds current in the range of -100 % to 100 % of the rated current for -10 V to 10 V. Input impedance: approx. 10 kΩ.	
	Setting accuracy	±(1 % of range) (TYP)
External voltage control input (superimposing in CC mode)	Controls the load setting of CC mode by adding current through external voltage input. Adds current in the range of -100 % to 100 % of the rated current for -10 V to 10 V. Input impedance: approx. 10 kΩ.	
	Setting accuracy	±(1 % of range) (TYP)
Load-on status output	ON when load is on. Open-collector output from a photocoupler. *1	
ALARM 1 output	ON when overvoltage detection, reverse-connection detection, overheat detection, alarm input detection, or parallel operation anomaly detection is activated. Open-collector output from a photocoupler. *1	
ALARM 2 output	Turns on when OCP, OPP, UVP, or WDP is activated. Open-collector output from a photocoupler. *1	
DIGITAL 0 output	Logic signal output during a step of a sequence. Output impedance: approx. 330 Ω. The thresholds are HIGH: 2.3V to 3.3 V, LOW: 0 V to 1.0 V.	
DIGITAL 1 output		
DIGITAL 2 input/output	Input/output switchable. Output: Logic signal output during a step of a sequence. Output impedance: 330 Ω. Input: Trigger input signal for the sequence and the measurement functions. The thresholds are HIGH: 2 V to 5 V, LOW: 0 V to 1.0 V.	
Current monitor output	Outputs 0 V to 10 V for 0 % to 100 % of the rated current. Output impedance: 1 kΩ (TYP)	
	Accuracy	±(1 % of range) (TYP)
All pins	800 V reinforced insulation between each pin and load terminals	

\*1 The maximum voltage that can be applied to the photocoupler is 30 V. The maximum current is 4 mA.

## ■ Sequence function

Item	PLZ12005WH	PLZ20005WH
Operation mode	CC, CR, CV, CP	
Maximum number of programs	30	
Maximum number of steps	10000	
Step execution time	50 μs ~ 3600000 s (50 μs ~ 1000 h)	
Time resolution	1μs	

## ■ Other functions

Item	PLZ12005WH	PLZ20005WH
Remote sensing	Input voltage rating*1	800 V *2
	Isolation voltage	±800 V
Number of units in parallel operation*3		5 units
		Load on/off
Mutual synchronized operation		Synchronization of sequence execution, and sequence resumption
		Recording timing of measured values
Elapsed time display		Displays the time from load on to load off.
	Range	0s to 3600000 s (1000h 0min 0s)
Ampere-hour meter display		Displays integrated current
	Range	0.000 mAh to 800.000 kWh
Watt-hour meter display		Displays integrated power
	Range	0.000 Wh to 400.000 MWh
Cutoff*4	Elapsed time	The load turns off when the elapsed time value reaches the specified value.
		Setting range
	Voltage drop	The load turns off when the voltmeter value reaches the specified value.
		Setting range
Integrated current	The load turns off when the ampere-hour meter value reaches the specified value.	
	Setting range	0.000 mAh to 800.000 kWh
Integrated power	The load turns off when the watt-hour meter value reaches the specified value.	
	Setting range	0.000 Wh to 400.000 MWh

\*1 There are limitations depending on the actual power that the load consumes.

\*2 A value obtained by adding the voltage between the load input terminals to the total potential difference between the positive and negative load input terminal and the SENSING terminals

\*3 The parallel operation terminal operates at the electric potential of the negative load terminal.

\*4 Multiple cutoff causes selectable

■ BNC connector

Item		PLZ12005WH	PLZ20005WH
Trigger output		Transmits 10 μs pulses during step execution when trigger output is set in a sequence. Transmits 10 μs pulses during pulse operation. Output impedance 200 Ω, output voltage HIGH: 2 V to 5 V, LOW: 0 V to 0.8 V.	
Current monitor output	Output voltage	0 V to 10 V for 0 % to 100 % of the rated current	
	Output impedance	50 Ω (TYP)	
	Accuracy	±(1 % of range)	
Voltage monitor output	Output voltage	1/100 of the measured voltage from 0 V to 8 V	
	Output impedance	50 Ω (TYP)	
	Accuracy	±(1 % of range)	
Isolation voltage		±30 V	

■ Communication function

Item		PLZ12005WH	PLZ20005WH
RS232C	Hardware	D-SUB 9-pin connector. Baud rate: 9600, 19200, 38400, 115200 bps. Data length: 8 bits, Stop bits: 1 bit, Parity bit: None Flow control: No, CTS-RTS	
	Message terminator	LF during reception, LF during transmission.	
USB (device)	Hardware	Standard type B socket. Complies with the USB 2.0 specification. Data rate: 480 Mbps (High Speed).	
	Message terminator	LF or EOM during reception, LF + EOM during transmission.	
	Device class	Complies with the USBTMC-USB488 device class specifications.	
USB (host)	Hardware	Standard type A socket Complies with the USB 2.0 specifications. Data rate: 480 Mbps (High Speed.)	
LAN	Hardware	IEEE 802.3 100Base-TX/10Base-T Ethernet IPv4, RJ-45 connector.	
	Compliant standards	LXI 1.4 Core Specification 2011	
	Communication protocol	VXI-11, HiSLIP, SCPI-RAW, SCPI-Telnet	
	Message terminator	VXI-11, HiSLIP: LF or END during reception, LF + END during transmission. SCPI-RAW: LF during reception, LF during transmission.	

■ General specifications

Item		PLZ12005WH	PLZ20005WH
Input voltage range		100 Vac to 240 Vac (90 Vac to 250 Vac) single phase	
Input frequency range		47 Hz to 63 Hz	
Power consumption		740 VAm <sub>ax</sub>	
Inrush current (peak value)		100 A or less (at cold start)	
Environmental conditions	Operating temperature range	0 °C to 40 °C	
	Operating humidity range	20 %rh to 85 %rh (no condensation)	
	Storage temperature range	-20 °C to 70 °C	
	Storage humidity range	90 %rh or less (no condensation)	
	Installation location	Indoor use, altitude of up to 2 000 m, overvoltage category II	
Insulation resistance	Primary ⇔ input terminals	1000 Vdc, 30 MΩ or more (70 %rh or less)	
	Primary ⇔ chassis		
	input terminals ⇔ chassis	500 Vdc, 30 MΩ or more (70 %rh or less)	
Withstanding voltage	Primary ⇔ input terminals	No abnormalities at 1500 Vac for 2 s.	
	Primary ⇔ chassis		
	input terminals ⇔ chassis	No abnormalities at 350 Vac for 2 s	
External dimensions		429.8(16.92)W×396.2(15.59)H×550(21.65)Dmm (inches)	429.8(16.92)W×573.5(22.57)H×550(21.65)Dmm (inches)
Weight		Approx. 64 kg	Approx. 93 kg
Accessories		Power cord(1 pc.,length:2.5m), Load input terminal cover(1 pc.), Load input terminal screw set(2 sets), Screws for the load input terminal cover(2 pcs.), External control connector kit, Safety terminal adapter [TL41] (red 1 set, black 1set), Parallel operation signal cable kit [PC02-PLZ-5W], Safety Information(1 pc.), Setup Guide(1 copy), Quick Reference(English/Japanese,1 sheet each), Heavy object warning label(1 pc.), CD-ROM(1 disc)	
Electromagnetic compatibility*1 *2		Complies with the requirements of the following directive and standards. EMC Directive 2014/30/EU EN 61326-1 (Class A*3) EN 55011 (Class A*3, Group 1*4) EN 61000-3-2, EN 61000-3-3 Applicable under the following conditions The maximum length of all cabling and wiring connected to the product must be less than 3 m.	
Safety *1		Complies with the requirements of the following directive and standards. EMC Directive 2014/35/EU*2 EN 61010-1 (Class I*5, Pollution Degree 2*6)	

\*1 Does not apply to specially ordered or modified products.

\*2 Only on models that have the CE marking on the panel.

\*3 This product conforms to Class A. This product is intended for use in an industrial environment. This product may cause interference if used in residential areas. Such use must be avoided unless the user takes special measures to reduce electromagnetic emissions to prevent interference to the reception of radio and television broadcasts.

\*4 This is a Group 1 instrument. This product does not generate and/or use intentionally radio-frequency energy, in the form of electromagnetic radiation, inductive and/or capacitive coupling, for the treatment of material or inspection/analysis purpose.

\*5 This product conforms to Class I. Be sure to ground the protective conductor terminal of this product. If not grounded properly, safety is not guaranteed.

\*6 Pollution is addition of foreign matter (solid, liquid or gaseous) that may produce a reduction of dielectric strength or surface resistivity. Pollution Degree 2 assumes that only non-conductive pollution will occur except for an occasional temporary conductivity caused by condensation.

■ External dimensions

Unit : mm (inches)

**PLZ12005WH**

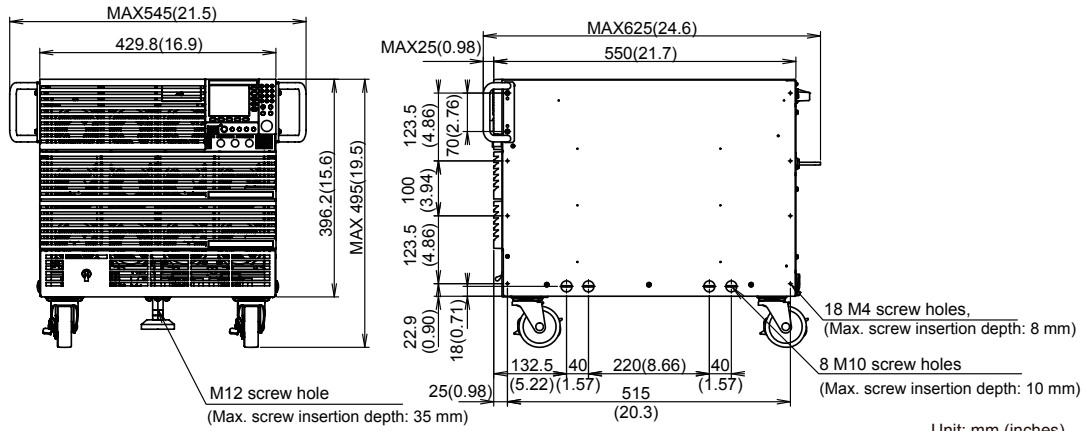

**PLZ20005WH**

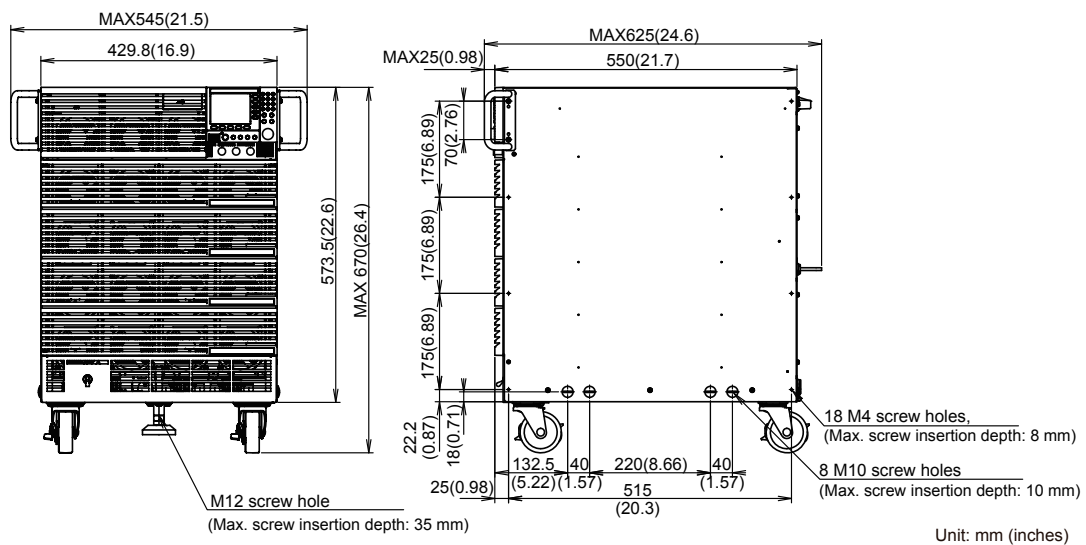

■ Options

**GPIB converter  
(PIA5100)**

This converter converts RS232C or USB of the PLZ-5WH to GPIB, enabling connection of a remote controller using GPIB.  
[Accessories: Power cord set, Magnetic sheet]



[Connection example]

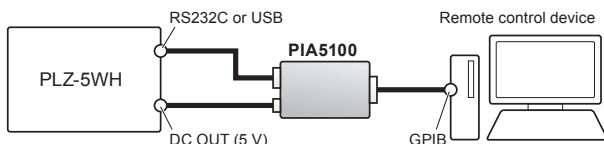

**Parallel operation signal cable kit  
(PC02-PLZ-5W)**

One cable required for each slave/booster unit.  
Cable length : 1m

\*This is an accessory. It is included as a spare for if the original is lost.

**Low inductance cable**

This is a load cable with suppressed inductance. It suppresses voltage drops that occur when current fluctuations are fast.

● Comming Soon

**Large current load cable**

This load cable supports large current. It supports currents up to 1000 A.

● Comming Soon

# Attaching rack mount brackets

These are rack mounting options.

## PLZ12005WH

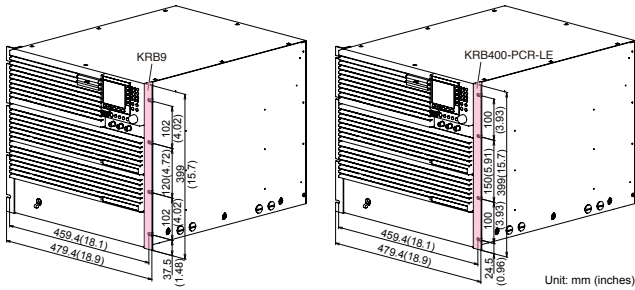

## PLZ20005WH

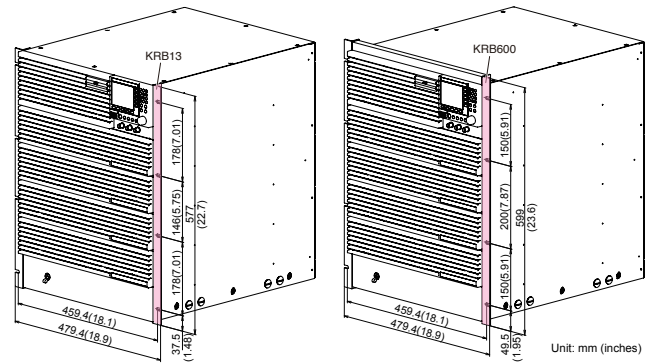

Name	Model	Appropriate Model	Description
Rack mount bracket	KRB9	PLZ120005WH	For EIA inch racks
	KRB400-PCR-LE		For JIS millimeter racks
	KRB13	PLZ20005WH	For EIA inch racks
	KRB600		For JIS millimeter racks



### KIKUSUI ELECTRONICS CORPORATION

Southwood 4F,6-1 Chigasaki-chuo,Tsuzuki-ku,Yokohama,224-0032,Japan  
 Phone: (+81)45-482-6353,Facsimile: (+81)45-482-6261,www.kikusui.co.jp

**KIKUSUI AMERICA, INC. 1-310-214-0000 [www.kikusuiamerica.com](http://www.kikusuiamerica.com)**



3625 Del Amo Blvd, Suite 160, Torrance, CA 90503  
 Phone : 310-214-0000 Facsimile : 310-214-0014

**KIKUSUI TRADING (SHANGHAI) Co., Ltd. [www.kikusui.cn](http://www.kikusui.cn)**



Room 305,Shenggao Building , No.137,Xianxia Road, Shanghai City, China  
 Phone : 021-5887-9067 Facsimile : 021-5887-9069

For our local sales distributors and representatives, please refer to "sales network" of our website.

●Distributor:

■ All products contained in this catalogue are equipment and devices that are premised on use under the supervision of qualified personnel, and are not designed or produced for home-use or use by general consumers. ■ Specifications, design and so forth are subject to change without prior notice to improve the quality. ■ Product names and prices are subject to change and production may be discontinued when necessary. ■ Product names, company names and brand names contained in this catalogue represent the respective registered trade name or trade mark. ■ Colors, textures and so forth of photographs shown in this catalogue may differ from actual products due to a limited fidelity in printing. ■ Although every effort has been made to provide the information as accurate as possible for this catalogue, certain details have unavoidably been omitted due to limitations in space. ■ If you find any misprints or errors in this catalogue, it would be appreciated if you would inform us. ■ Please contact our distributors to confirm specifications, price, accessories or anything that may be unclear when placing an order or concluding a purchasing agreement.